

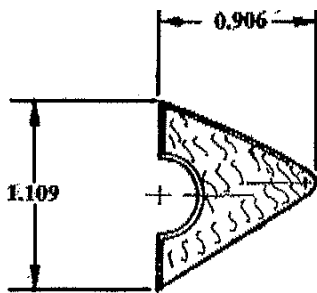

## Cushion Rail Information Panther Update



Valley-Dynamo has used three different profiles of cushion rail rubber: U-23, K-55 and the current spec – K-66. When changing your rail sets it is critical that the profile is consistent. Valley switched from U-23 to K-55 in 1989 and from K-55 to K-66 in 1999. Dynamo switched between K-55 and K-66 several times, based on player and Operator preference.



*U-23—prior to 1989*

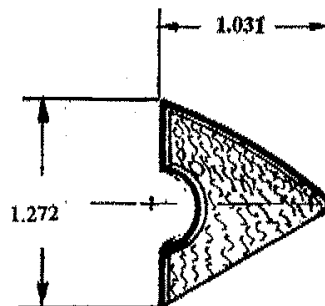

*K-55—1989-1999*

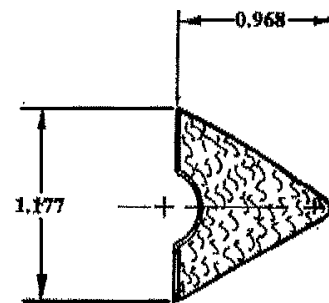

*K-66—current use*

**Our Dual Density K-66 rubber is optimized for shot accuracy, but may not play as fast as other rubber profiles. Based primarily on feedback received from Tournament play, this is our rubber of choice for new production tables and replacement cushion rails.**

All rail rubber is date coded. We also began stamping the profile and date on the wood rail in 2002 to make it easier for Operators to keep sets matched. All packed boxes of genuine Valley-Dynamo rails are date stamped, and all sets since 2009 now have a Richland Hills TX stamp.



Playing with mismatched rails is like hitting the Basketball court with one Air Jordan and one Converse All-Star. Someone watching may or may not notice, but if you're the one playing, you will notice... big-time!



## **The Valley Panther tables introduce our new 5-bolt Rail System (patent pending)**

### **What's different?**

Two additional rail-bolt attachment points added  
Now using Threaded Inserts instead of T-nuts  
Small dead spots in rubber now eliminated

**What are the advantages to the new system?** First, going to a five-bolt system on the new Valley Panther and Panther ZD-X tables allows for more secure attachment without risking overtightening the bolts. Now if one rail bolt backs out, comes loose, breaks, FOUR Bolts shoulder the rest of the load instead of two, and the load is evenly distributed. Second, the Threaded Inserts can be more easily replaced in the field and are less likely to strip. Third, the threaded inserts allowed us to eliminate the gaps shown in the photo at left. The small dead spots these gaps allowed are now gone, and the cushion rail rubber can do its job more effectively.

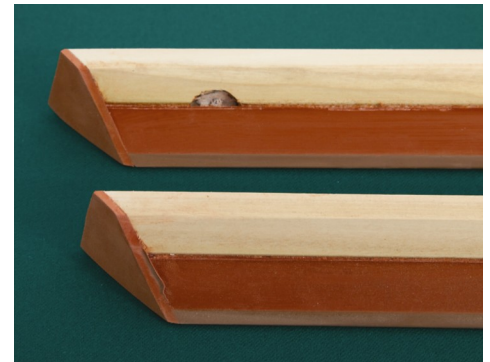

**What are the disadvantages?** Here's the good part: NONE. These new five-bolt rails even cost the same as the old three-bolt design.

**Will the new rails fit my existing table?** YES. We kept the center and outermost bolt locations unchanged. If your table uses three bolt rails, the five bolt rails should fit just fine. For tables built prior to 1998, the same rules apply for using newer rails on older tables. The table modification procedure—outlined in our Pool School—is unchanged. Likewise, for old tables where the rails attach with wood screws, these rails will also not work.

**Can I modify my table so the Cushion Rails attach with five bolts?** Specialized CNC equipment ensures the bolt holes are correctly located on new tables. While modifying an older table is possible, it is not recommended.

**Has the rubber changed?** Definitely not! The Valley Panther 5-bolt rail system uses the same K-66 Dual-Density cushion rubber by Championship. The Dual-Density rubber provides an ideal combination of responsiveness, accuracy, and long-term durability.

**WHAT REALLY IS THE PROPER CUSHION RAIL HEIGHT?** – A frequently-asked-question if ever there was one. BCA Specifications are 60% - 64% of the height of the object ball, or more simply measured: 1 7/16" above the bed of the table. Many people align the cushion rail even with the top rail laminate—which should put the rails at the bottom-end of the specification. Valley-Dynamo sets rails at the top-end of the specification from the factory. This allows an operator to use unbacked bed cloth on the slate but still keeps the nose of the cushion within specifications and above the top rail laminate. In our years of experience, a higher setting keeps balls from “jumping” off of the table just as easy as the lower setting. (Flying pool balls are usually not appreciated in your local tavern). If you prefer to increase the speed or bounce of your rails, set them lower... at your own risk.

The first step for any complaints about “dead” cushion rails should be to measure the height and verify it is within specs. Rails mounted too high will play dead. The best tires in the world will ride horribly if not mounted and balanced properly.

**ABOUT DUAL DENSITY RUBBER:** The Championship Dual Density rubber used on Valley cushion rails is designed for accuracy, consistent shots and long life. Other rails' rubbers are designed for maximum bounce above all else, at the expense of accuracy.

**Tournament players prefer consistent, accurate shots.**

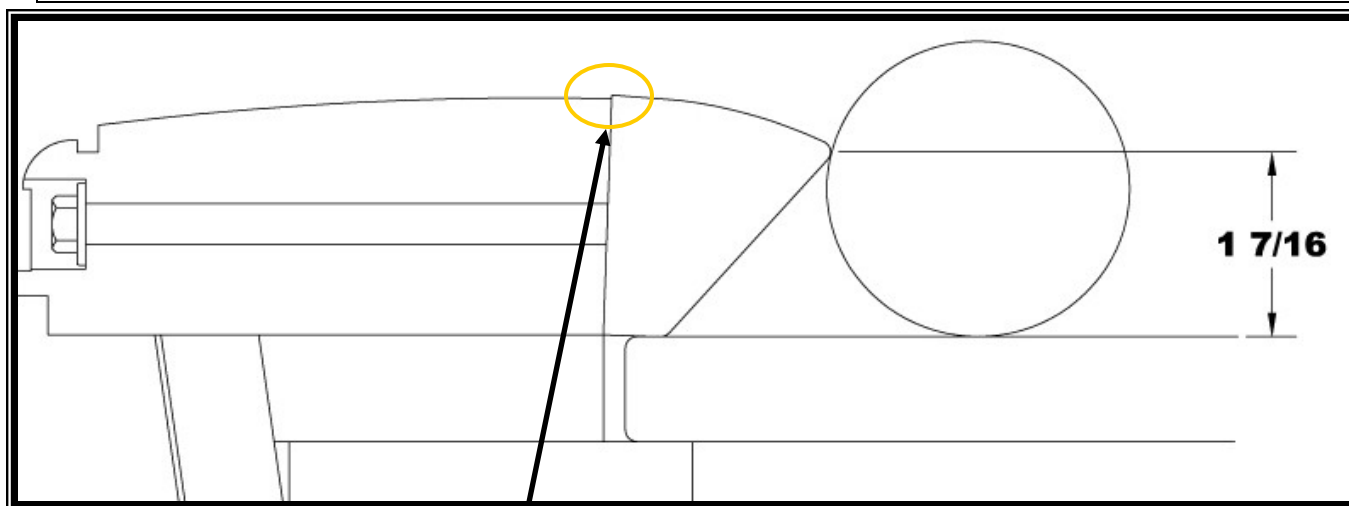

**THEY STILL LOOK A LITTLE HIGH TO ME:** Sometimes, the cushions may be as much as 1/16" higher than the rail laminate. **NOT A PROBLEM.** Rail height is measured from the slate surface up. If you set the cushions so they are flush with the rail laminate and ignore the crucial measurement from the slate surface, you increase the chance of balls bouncing over the cushions— and onto your players!

**... BUT THEY STILL LOOK A LITTLE HIGH TO ME:** The wood backing on our cushion rails extends into the groove between slate and side wall for more solid mounting of both slate and rail.

Also, the accumulation of glue on the slate from repeated recovering over time raises the surface. It's important to strip the slate of excess glue when recovering.

**HOW TIGHT IS NOT TIGHT ENOUGH?** Players' complaints about "dead rails" may be easily solved with simple tightening of the rail bolts. We are frequently asked how tight the rails should be. Experience has found that **65 inch-pounds** of torque provides the optimum tightness for cushion rails. This setting assures the rails can stay set at the recommended height and maintain the expected rebound properties (although proper mounting is a much bigger factor in play quality than tightening the rail bolts to specifications). **To avoid cross-threading your rail bolts, MAKE SURE YOU START THE BOLTS BEFORE FULLY TIGHTENING to torque specs.** Cross-threaded bolts are not a covered warranty failure.

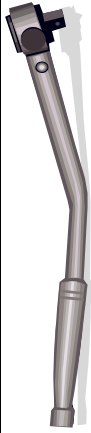

Also, check your rail height as shown on page 3. Rails mounted too high can also result in dead action. Finally, rails that may seem dead could have experienced separation in the glue bond attaching the rail and wood. Strip the rubber away from the wood, clean the old glue residue from both surfaces, and re-glue to solve the problem. The cushion rails on a table in heavy use for more than 18 months will begin to lose their bounce. Consider restoring the table's play with a new set of Genuine Valley-Dynamo rails—they are available pre-covered, or uncovered (most sizes) so you may use your choice of cloth.

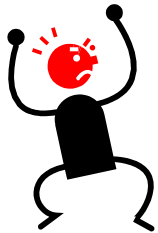

**"GRRR, YOUR CUSHION RAILS ARE WORTHLESS, AS SOON AS I PUT THEM ON THE RUBBER STARTS SEPARATING FROM THE WOOD!! @\$%&!!"**

We've heard this one and while the occasional rail set reaches a customer with a problem, many times this is caused by...

**Possibly Overtightening *this set of rails*.** Strip the rubber away from the wood, clean the old glue residue from both surfaces, and re-glue to solve the problem, and next time go easier on them.

or

**Usually Overtightening rails repeatedly in the past.** The tightened rail bolts gradually dug into the wood, so now a rail tightened to normal specs will be a little too deep. If this is the problem, repair as noted above, and simply add a few more washers before tightening the rail bolt to allow for proper spacing.

Always be mindful, rails should be snug— but not Ironman tight. The most important factor in quality play is proper alignment.

## INSTALLING REPLACEMENT RAILS ON OLDER-MODEL VALLEY TABLES

The current Valley rails will only fit tables using rail bolts to attach the rails (beginning with the model 510 series: from late 1969-present). If the rails are attached with wood screws, the best option will be to have the rubber replaced on the current rails, and have them covered in new felt. If your Valley table is of 1970-1995 vintage, your table will require this minor modification for the current-model rails to fit.

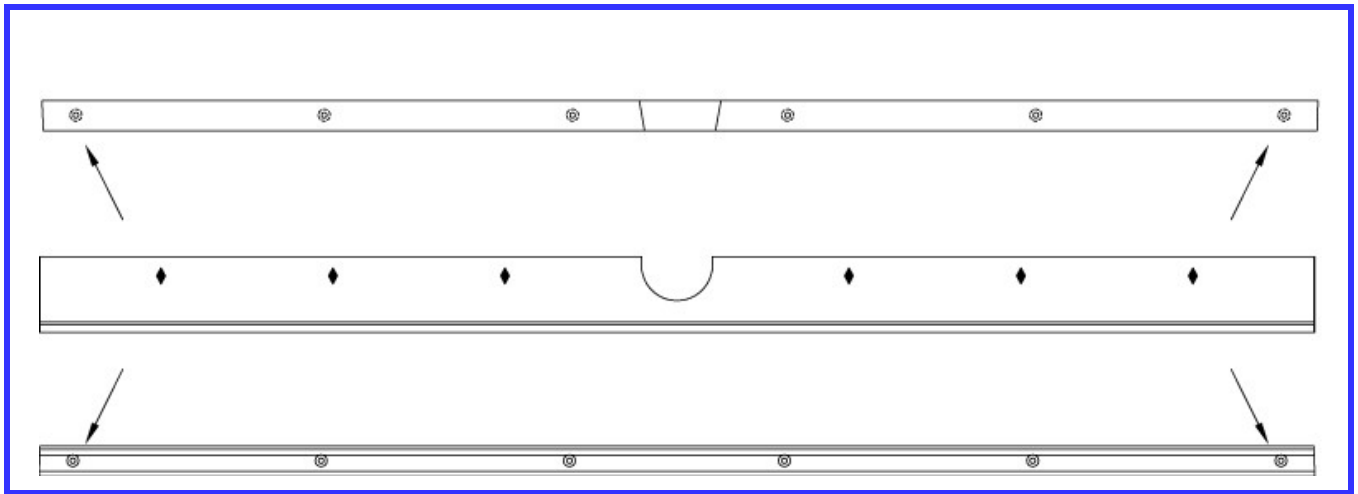

Drill the end mounting holes on the side rail using a  $\frac{3}{8}$ " diameter drill bit. From the cushion side, drill no deeper than  $1 \frac{3}{64}$ ". This will allow just enough movement of the rail bolt so it can be angled to attach to the current-model cushion rails.

