



Valley Dynamo

BLACK HOLE

Service Manual and Instructions



7115 Belton St.
Richland Hills, TX 76118
972.595.5300

sales@valley-dynamo.com

For International Sales:
international@valley-dynamo.com

See the full Valley Dynamo product line at
www.valley-dynamo.com



Valley-Dynamo Companies





Contents

- 3 – Warranty
- 6 – Declaration of Conformity
- 6 – Warnings and notices
- 7 – Assembly instructions
- 13 – Overhead instructions
- 17 – Side Shield Installation
- 18 – Black Hole Programming
- 20 – Electronics Layout
- 23 – Ticket and Cardreader Installation
- 24 – Selected Parts Listing
- 26 - Rules of Play
- 28 – Routine Maintenance
- 30 – Closing Notes



This manual is Valley-Dynamo part # 850400410 – Jun 2018 rev

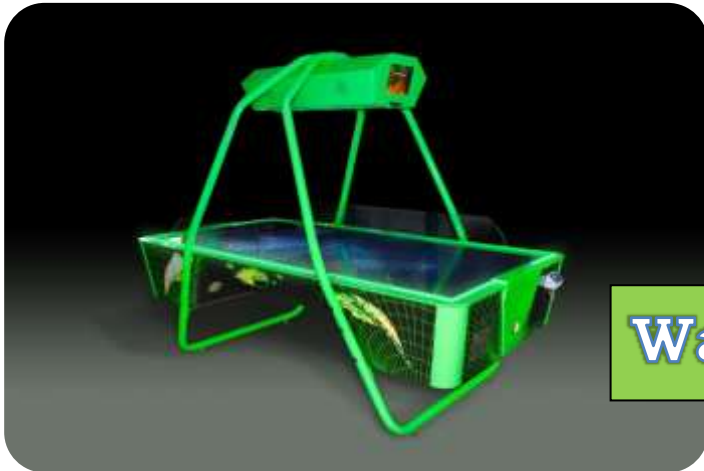

Warranty Details

Valley-Dynamo warrants its new products to be free from defects resulting from faulty manufacture or faulty components under the following terms and conditions:

WARRANTY LENGTH

One year on Dynamo® Hockey tables. **90 days** on Replacement Parts

FOR WARRANTY SERVICE

Valley-Dynamo will, at its sole option, repair, upgrade or replace this product in the event of any defect in materials or workmanship during the warranty period. This shall be Valley-Dynamo's sole obligation, and the customer's sole remedy, for any warranty claim.

Valley-Dynamo will request and you must provide the **complete Model Number & Serial Number of the unit** located inside the Black Hole's CPU ACCESS Door, or other proof of purchase such as an invoice or receipt.

OPERATORS AND END USERS – While our Tech Support staff is available to assist with diagnosis and troubleshooting of your problem, contact your Distributor for Warranty Service on your equipment.

DEALERS AND DISTRIBUTORS – To obtain replacement and an RMA number, contact Valley-Dynamo referencing the Model number and Serial number of the unit and the nature of the problem. Valley-Dynamo will, at its discretion, send replacement parts and/or issue an RMA for the return of failed parts. To avoid billing issues, request an RMA when the failed part is present or readily available. Credit will be issued only upon receipt and inspection of the RMA. Valley-Dynamo may send replacement parts or issue

an account credit. **NO REFUNDS.** Valley-Dynamo reserves the right to cancel outstanding RMAs 30 days after issue. Items returned with no RMA will not be inspected or credited and may be refused or returned at Customer Expense.

REPLACEMENT PARTS COVERAGE – Valley-Dynamo warrants replacement parts for 90 days from the date of purchase. To obtain a replacement and an RMA number, contact Valley-Dynamo referencing the nature of the problem and provide proof of purchase. Valley-Dynamo will, at its discretion, send replacement parts and/or issue an RMA for the return of failed parts. To avoid billing issues, request an RMA when the failed part is present or readily available. Upon receipt and inspection of the RMA, Valley-Dynamo may send replacement parts or issue an account credit. **NO REFUNDS.** Valley-Dynamo reserves the right to cancel outstanding RMAs 30 days after issue. Items returned without an RMA will not be inspected or credited and may be refused or returned at Customer Expense.

SCOPE OF COVERAGE

Note that our warranty is not an unconditional guarantee for the duration. Dynamo products are made to our exacting standards and known for their durability, but are not indestructible and may require periodic maintenance in order to function properly. The following are not covered by the warranty.

- 1) Shipping or transport damage
- 2) Normal wear and tear
- 3) Damage or deterioration resulting from neglect, misuse, accident, liquid spills, improper installation, abuse, pets, burns or mishandling

Hockey Playfields - *The most frequent cause of warpage or laminate separation on a playfield is a liquid spill. Liquid spills are not a covered warranty failure. If warranty failure is suspected, for evaluation Valley-Dynamo will require return of the damaged playfield or at minimum at least 12 square feet (4' x 3') of the damaged section. No credit will be issued for a Playfield damaged by a liquid spill, or for incoming or outgoing freight for the replacement or returned playfield.*

- 4) Damage due to Power Surge – Valley Dynamo recommends using a surge protector several places in the manual. It's important!!
- 5) Incidental or consequential damage (except at Valley-Dynamo's discretion).
- 6) Removal or installation charges.
- 7) Shipping charges except at Valley-Dynamo's discretion.
- 8) Unauthorized modification of the product.
- 9) Use of this product with unapproved parts, conversion kits or accessories.
- 10) Damage from fire, flood, lightning or other acts of nature
- 11) Bulb failure or breakage

EXCLUSION OF DAMAGES

Valley-Dynamo’s sole obligation and liability under this warranty is limited to the repair or replacement of a defective product at our option. Valley-Dynamo shall not, in any event, be liable for any incidental or consequential damages resulting from interruption of service, loss of business or revenue, or for liability in tort relating to this product or resulting from its use or possession.

LIMITATIONS OF IMPLIED WARRANTIES

There are no other warranties, expressed or implied, including but not limited to those of merchantability, revenue generation, or fitness for a particular purpose. The duration of implied warranties is limited to the period specified in the Warranty Length section above.

TO OBTAIN TECHNICAL SUPPORT

Please check the resources available at www.valleydynamoparts.com or contact TECHHELP@valley-dynamo.com.

DECLARATION OF CONFORMITY

Dynamo, Ltd.

2525 Handley-Ederville Rd., Richland Hills, TX 76118

declare under our sole responsibility that the product

DH-100

to which this declaration relates is in conformity with the following standard(s) or other normative document(s)

- ◆ EN 55022, Class B, Limits and methods of measurement of radio interference characteristics of information technology equipment, 1992.
- ◆ EN 50082-1, Electromagnetic compatibility - Generic immunity standard – Part 1: Residential, commercial, and light industry, January 1992.

following the provisions of The Electromagnetic Compatibility Directive, 89/33/EEC.

<i>Richland Hills, TX</i>	William G. Rickett
Place of Issuance	Printed Name
November 17, 1995	
Date of Issuance	Signature of Authorized Person





Warnings and Notices

USE OF NON-DYNAMO PARTS OR CIRCUIT MODIFICATIONS MAY CAUSE SERIOUS INJURY OR EQUIPMENT DAMAGE! USE ONLY GENUINE DYNAMO AUTHORIZED PARTS.

- For safety and reliability, substitute parts and modifications are not recommended.
- Substitute parts or modifications may void FCC type acceptance.
- Use only authorized components and parts. Failure to do so will void warranty and may result in incorrect and/or unsafe operation.

WARNING

- Plug this game into a properly grounded outlet to prevent shock hazards and assure proper game operation.
- Use a surge protector. The Black Hole electronics are more sophisticated and sensitive as those in our other hockey tables. You'd use a surge protector on your computer, you should use one on your Black Hole Hockey table.
- Do not use an adapter plug to defeat the power cord's grounding pin.
- Do not cut off ground pin.

Information in this manual is subject to change without notice. Dynamo reserves the right to make improvements in the equipment function, design or components as progress in the engineering or manufacturing methods may warrant.

FOR GENUINE DYNAMO PARTS AND SERVICE CONTACT YOUR AUTHORIZED DYNAMO DISTRIBUTOR.

PARTS CAN ALSO BE ORDERED AT WWW.VALLEYDYNAMOPARTS.COM



Assembly Instructions

Congratulations on purchasing a Dynamo Hockey table - the finest professional grade hockey table on the market.

BE SAFE: it is strongly recommended that you have at least two people for the safe setup of our hockey tables.

The keys to open the coin and service doors are found with the instruction manual, taped to the playfield protective pad.



Recommended tools:

- Drill
- Ratchet
- 12" extension
- ½" Socket
- ½" open-end wrench
- Adjustable wrench
- Band cutters
- Wire Cutters
- Phillips Screw Driver
- Rubber Mallet

Lay the box flat on the floor, mindful of the section labeled "This Side Up." Cut the banding straps and remove the top portion of the box completely. Lower the sides of the box bottom by carefully cutting or tearing vertically at all of the corners. Remove all staples from the box top and bottom, retain the box top as it will be used later.

Note that we will refer to the COIN DOOR END of the table as the BLUE and HOME end.

The EXTERIOR SERVICE DOOR is located on the end opposite the coin door, also referred to as the RED or VISITOR end. Open this door and remove the parts kits.



Parts Kits

- 1x **CAMERA BRACKET WITH CAMERAS**

Game Play Pack

- 2 860400210 mallets
- 2 860400090 pucks
- 2 980400200 sand paper disks

Wire Harnesses

- 1 730409010 main overhead tube harness
- 1 Overhead AC harness
- 1 Power Cord

Overhead Diffusers

- 2 800404905 Diffuser expanded metal screens
- 2 800404910 Bracket Diffuser

Leg Hardware kit

- 4x 870000124 8-32 x 5/8 screws
- 4x 870046103 Washer # 10
- 12x 870007390 5/16 bolts
- 12x 800404935 spacers
- 12x 870050106 Washers
- 4x 20300110 5/16 nuts
- 4x 870401000 Leg Levelers



Black Hole Assembly Video link

The Black Hole is the most sophisticated and complex Hockey table Dynamo has yet offered, and will be challenging to assemble the first time. **It is NOT the "same old" Dynamo table you may be accustomed to.**

We posted a video on the ValleyDynamoTV YouTube page to demonstrate hard-to-describe portions of the assembly process. Search YouTube for ValleyDynamoTV, or scan the QR code at right to go directly to the video.

For best results, have the manual AND video available for reference.



Removal of the Overhead Display Unit.

The hockey table should now be carefully lifted onto its side (the end with the coin door will be to your left, the end with the service door to your right). Have two people tilt the table from the **ends**, **do not lift from one side**. **The table could land on you and cause injury if you lose your grip while lifting the table from its side.**

With the table on its side, you can see the four 5/16" bolts securing the Overhead Display Unit to the underside of the table. Use the ratchet, 12" extension and 1/2" socket, take care not to damage the fluorescent light bulbs in the fixture, and remove the four bolts to free the Overhead Display Unit. Carefully store the Overhead Display Unit for later use. The attachment bolts will not be needed again.

Set the table back down, still using the box bottom as a base.

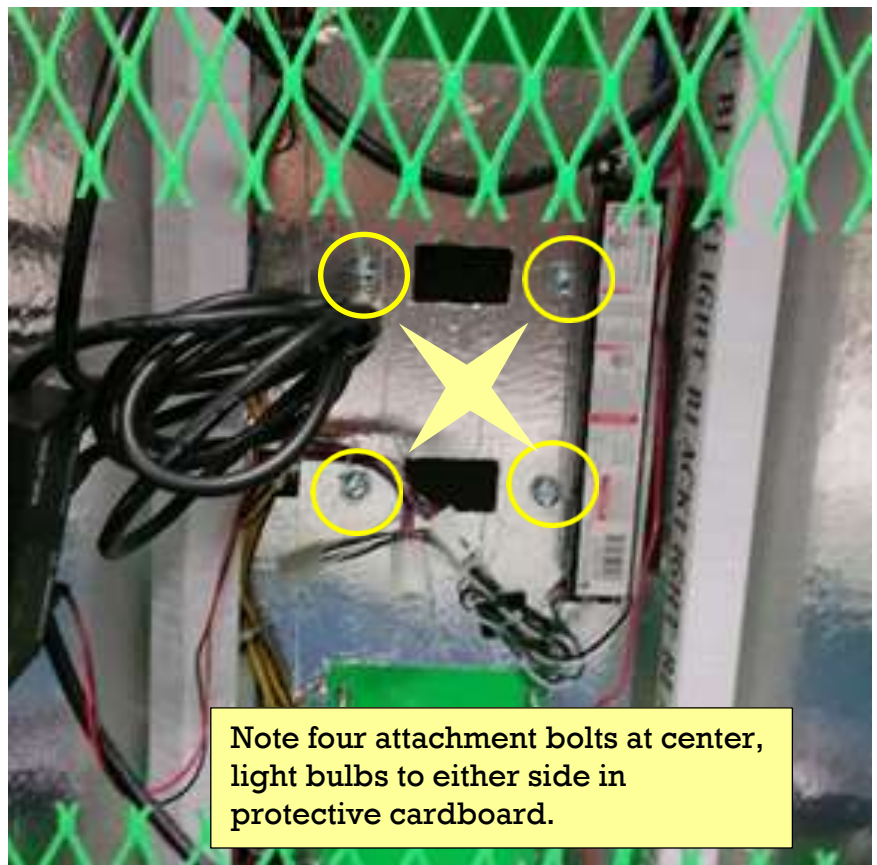

The Secondary Box contains four overhead tubes (two male, two female) and two U-shaped Legs. Slide the U-shaped legs under the central opening, opposing each other in this manner as shown in the photo below, with the leg leveler openings facing up.



Note in the photo detail each leg has **THREE** mounting holes, and the side of the table has **THREE** corresponding holes. Each leg also has a Wiring Access Hole corresponding to the square hole in the cabinet.

At this point in the assembly process, use *only* the lowest hole in the table and the lowest hole in the leg. This is the pivot point for the legs.

While pulling the leg away from the table side,

carefully slide one bushing between the leg and the table side wall. Insert one 5/16" leg mounting bolt and washer through the leg and thread it into the lowest leg mounting hole on the table's side wall.

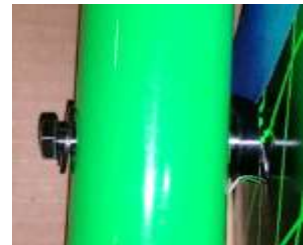

Pressure from the leg will hold the bearing tightly to the table's side wall, so take care when moving the table or adjusting the leg position to avoid damage to the side decal.

Turn the bolt by hand two or three turns to secure the leg but **AGAIN DO NOT FULLY TIGHTEN THE BOLT**. Repeat the process with the same holes on the opposite side of this leg. Then attach the table's right leg in the same manner, remaining careful of the side wall decal, and hand tightening the bolts 2 or 3 turns.

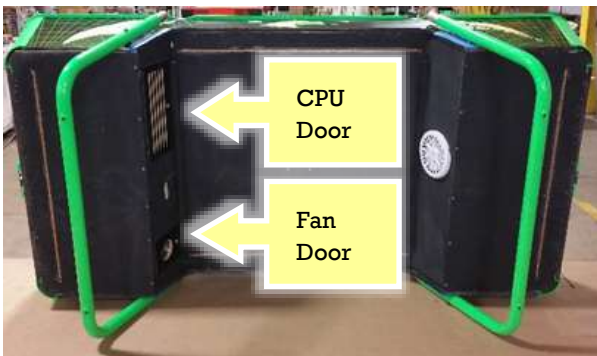

Once both legs have been attached at all four points and may fully hand tighten all four leg bolts but **DO NOT FULLY TIGHTEN THEM UNTIL THE OVERHEAD HAS BEEN INSTALLED**, have two people lift the table back onto its side: coin door end to the left, service access door end to the right. **CPU ACCESS DOOR** to the upper left, **FAN DOOR** to the lower left.

Position the box top saved from unpacking the table on the floor, near the legs.



Now, rotate the legs so the two other bolt holes from the photo line up with the corresponding holes in the table. The legs should be at roughly a 45-degree angle to the table, with the leg leveler openings should be parallel to the bottom of the table and flat to the floor. Install the four leg levelers.



Use a #106 key to open the CPU ACCESS DOOR (see photo) on the bottom surface of the table.

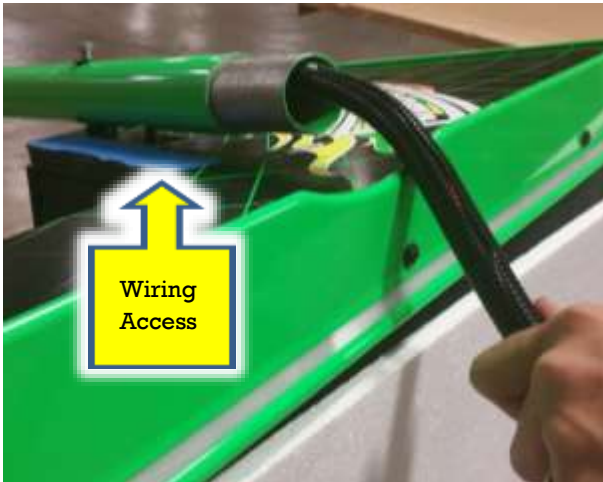

Take the Overhead Wire Harness from the Parts Kit. Feed the end marked "TABLE SIDE / A" into the leg closest to the CPU Access Door and into the table using the Wiring Access Hole in the leg and cabinet.

From the CPU Access Door, pull the Overhead Wire Harness into the table cavity.

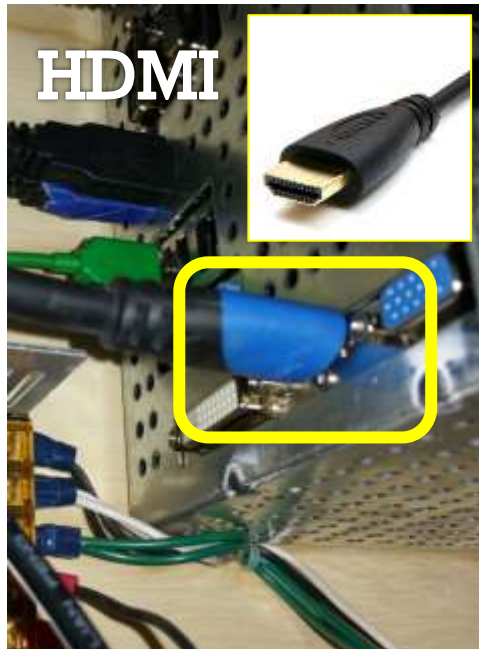
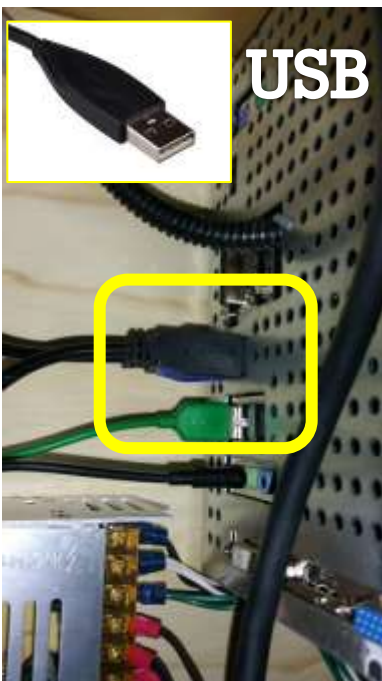

Plug two USB Connectors into the Motherboard Ports as shown to the left (either connector can plug into either USB port on the motherboard)

Then connect the HDMI video to the Motherboard Port as shown to the right.

Last, plug the white 4-pin and 6-pin connectors to the available open

connections in the CPU Access panel



At this point in the assembly process, use the center hole in the table and the leg.

Pull the leg away from the table and slide one bushing between the leg and the table side wall. Take care when installing the bushing to keep from damaging the side decal. Insert one 5/16" leg mounting bolt and washer through the leg and thread it into the upper leg mounting hole on the table's side wall.



Repeat this process for the other leg, then tilt the table to where the bolts just inserted face down and the other side of the table faces up. The CPU ACCESS DOOR should now be to the lower right, and FAN DOOR should be to the upper right.

Use a #106 key to open the FAN DOOR (see photos) on the bottom surface of the table.



Take the Overhead AC Harness from the Parts Kit. Feed the end marked "TABLE SIDE / B" into the leg closest to the Fan Door and into the table using the Wiring Access Hole in the leg and cabinet.

Now repeat the process for attaching the leg to the table using the center hole in the leg and table.

Place one bushing between the leg and the table side wall. Take care when installing the bushing to keep from damaging the side decal. Slide one 5/16" leg mounting bolt and washer through the leg and thread it into the upper leg mounting hole on the table's side wall. **MAKE SURE ALL 8 BOLTS ARE SNUG BUT DO NOT FULLY TIGHTEN THE LEG BOLTS YET – YOU WILL DO THAT ONCE THE UPPER OVERHEAD TUBES ARE FULLY INSTALLED.**

You may now set the table upright on its legs..



Installing the Overhead Mounting Tubes. Keep the wire harnesses accessible as they will need to be fed into the overhead mounting tubes and plugged into the Overhead Display Unit.

FIRST : route the Overhead Wire Harness through a FEMALE mounting tube. There is a cut-out at the top of the tube for the wiring, Slide the female tube onto the lower U-shaped leg.

SECOND : on the opposite side of the table, route the Overhead AC Harness through a MALE mounting tube. Slide the male tube onto the lower U-shaped leg and assemble the tops of the tubes, taking care that the wire harnesses are accessible and have not been crimped.

The hole under the tube should be parallel to the playfield.



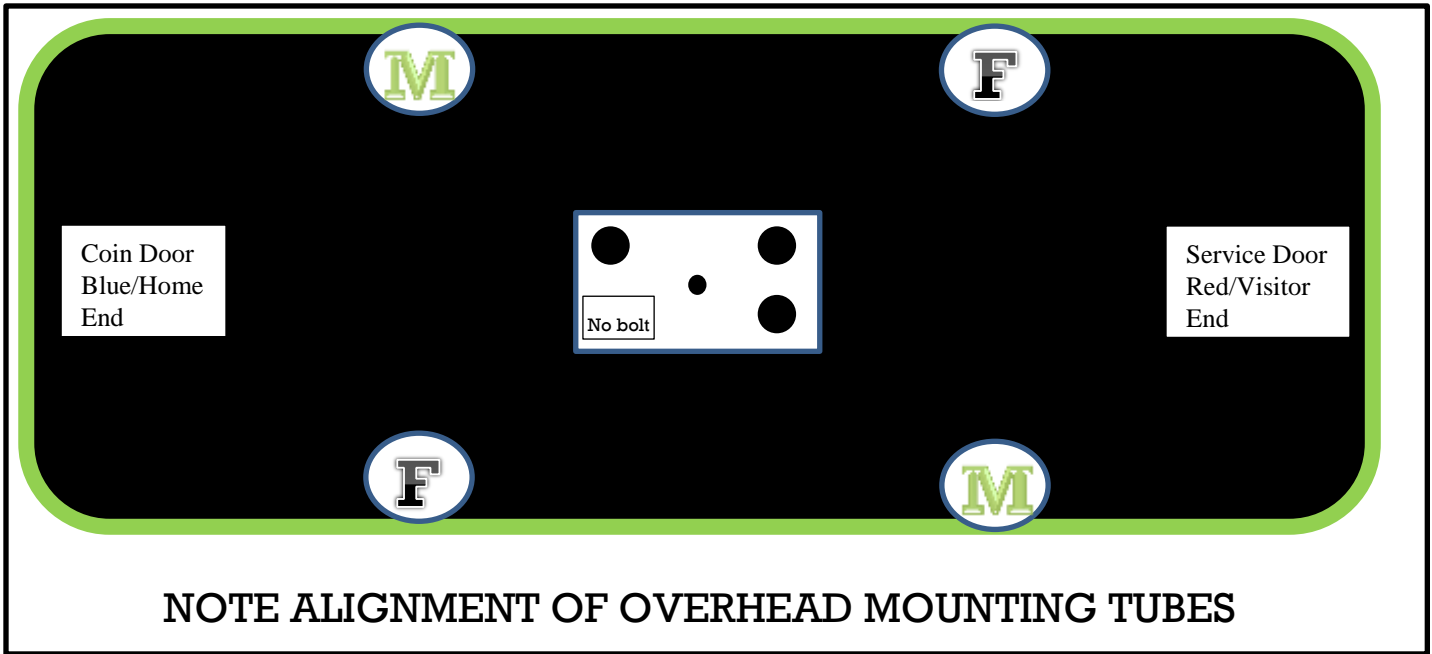

THIRD : Install Female and Male overhead mounting tubes on opposite sides of the table as used on the first two, use the diagram above as your guide. Now, all four mounting tubes should be installed on the table, with the wire harness accessible.



Install the third mounting bolt in each of the four legs to secure the overhead mounting tubes to the legs. As with the first eight leg bolts, use the bushings and take care to prevent the bushing from damaging the side decal.



The overhead bracket will have **THREE** bolts installed to secure it. Align the bracket so the corner **WITHOUT** the bolt corresponds to the overhead mounting tube containing the Overhead Wire Harness (note diagram above).



Tap the bracket with the rubber mallet to install it atop the Overhead Mounting Tubes.

Continue to watch that the wire harnesses are not pinched, crimped or otherwise restrained during the assembly process.



Installing the Overhead Display Unit

Use care during this step, dropping the overhead onto the playfield will almost certainly damage the playfield and render the game unplayable. If the table is in the normal, upright position, we recommend having TWO people to support Overhead Display Unit for installation while a third person secures the overhead with nuts and washers. **DROPPING AN OVERHEAD ONTO A PLAYFIELD IS NOT A COVERED WARRANTY DEFECT.**

We also suggest removing the overhead bulbs during installation, or using a 12" extension to reach the bolts, but still leaving the protective cardboard on the fluorescent bulbs.

One end of the overhead will have a Directional Indicator marker. **THAT END OF THE OVERHEAD SHOULD BE ORIENTED TOWARD THE COIN DOOR END OF YOUR BLACK HOLE TABLE.**

Feed the Overhead AC Harness and Overhead Wire Harness through the rectangular cut out. Then, secure the four nuts and washers attaching the overhead with the ½" socket (and the 12" extension).

Connect the Overhead Wire Harness HDMI cable to the Splitter Input Connection, and the 6, 4 and 3 pin connectors to their corresponding plugs in the overhead.



At this point you may remove the protective cardboard from the Fluorescent Lamps, or reinstall the lamps if you removed them for safety while attaching the Overhead Display Unit.



Installing the Overhead Display Unit Camera Bracket



On either side of the Camera Bracket are three mounting tabs. Slide the three tabs on one side of the camera bracket into the groove located inside the Overhead Display Unit. Next, pull out on the Overhead Display Unit wall closest to you to slip the three tabs on the other side of the Camera Bracket (as in “the side now closest to you that is not already anchored in a groove”) into the groove.



You may now connect the USB Extension harness into the marked camera connections,

Plug in the game and test for power up and functionality. As with a computer, “gibberish displays” can result if the video cables are not fully connected. For any display problems, **ALWAYS CHECK YOUR CONNECTIONS.**

Install the safety diffuser grating and locking brackets on the Overhead Display Unit, fully tighten all leg bolts, and secure all service doors.

This game is more complex and sophisticated than prior Dynamo tables, and far more sensitive to power surges. To avoid damage and down time, we **STRONGLY** urge use of a Surge Protector on your Black Hole Hockey table.



Side-Shield Installation

Dynamo's 3-piece Shield set will help to keep the puck on the table and discourage the placement of drinks on the table's side rails. While it will create a safer environment, no shield has been invented that will keep every puck on every playfield every time. Exercise caution during play, keep hands and fingers clear of the playfield, and follow the instructions from Dynamo Caution Label, part # 850404030

Kit Contents:

- Side Shields 2
- Center Shield 1
- Rubber Grommets 18
- 10-32 x 1½" Black Oxide Hex Bolts 4
- Lock nuts 4
- #10 Black Oxide Washers 8

Tool required

- Phillips Screwdriver

1. Remove the bolts from the Side Top Rail, except for the bolt at the very end of each Rail.
2. Insert Rubber Grommets into the holes from the top of each Side Shield
3. Mount with the flange of the Shields to the outside.
4. Re-install the Top Rail bolts previously removed, start them by hand but do not fully tighten until all bolts have been started and the center shield has been installed.
5. Install (2) Rubber Grommets in each of the Side Shields, from the outside
6. Install the Center Shield by aligning it with the two holes in each Side Shield: flat side down, arched side up. Hand thread the 4 bolts to avoid breaking them. Fully tighten all bolts once installed.
7. Remove the shields for periodic cleaning. Use a standard glass/window cleaner, harsh chemicals can degrade the rubber grommets.

CAUTION-TO PREVENT PUCK FROM FLYING OFF TABLE AND CAUSING POSSIBLE INJURY, BE SURE THE PUCK IS LAYING FLAT ON THE TABLE SURFACE BEFORE STRIKING WITH Mallet AND USE ONLY DYNAMO MANUFACTURED PARTS.



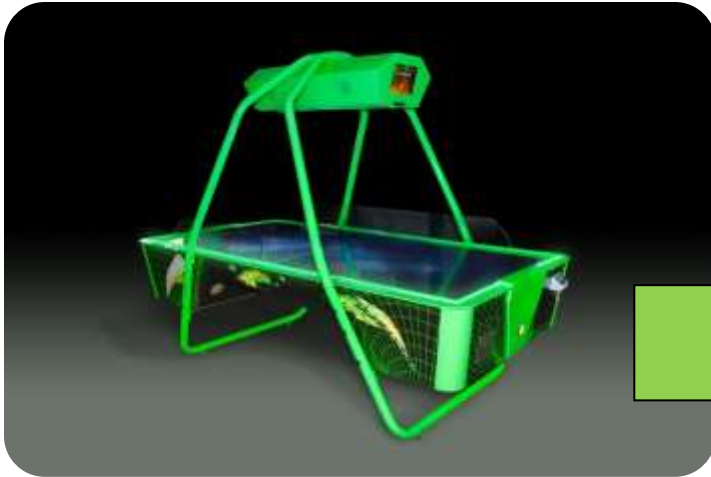

Programming

The Black Hole is shipped with a keyboard located behind the cash box. You may also use any USB keyboard. Open the CPU Access Door and plug the keyboard into an open USB slot of the mother board. Press M to enter programming mode.



The Overhead Display Screens make programming easier than ever for a Dynamo Hockey table, no cryptic codes of two-digit readouts, no microscopic access buttons on the CPU Boards. Programming is less complicated, more flexible, and MUCH more user friendly.

To navigate through the options

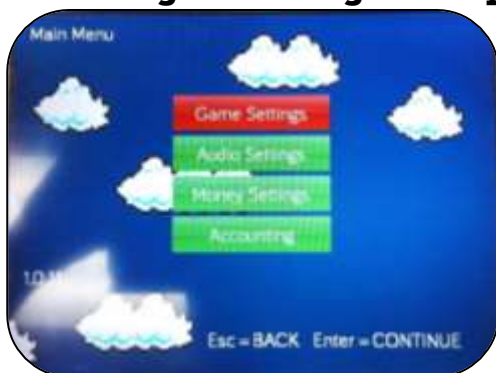

- Use the Up or Down Arrow to scroll through the options
- Use the enter key to select and open the option you want to change
- Use the Left and Right Arrow keys to increase or decrease the value selected

Available Values

Money:

- base: [0.05 - 20.00] increments of 0.05
- currency: USD, AUD, GBP, JPY, CAD, HKD, CHF
- clicks: [1 - 20] increments of 1
- card swipe: On/Off (press space bar to toggle)
- price (for card swipe): [0.00 - 20.00] increments of 0.05

Game:

- time limit: [1 - 30] increments of 1
- score limit: [1 - 30] increments of 1
- tickets: On/Off
- ticket type: Per Game/Per Score
- winner tickets: [0 - 100] increments of 1
- loser tickets: [0 - 100] increments of 1
- attract time: [1-60] increments of 1

Audio:

- music: On/Off
- music volume: [0 - 100] increments of 1
- sound fx: On/Off
- sound volume: [0 - 100] increments of 1
- microphones: On/Off
- mic sensitivity: [0 - 100] increments of 1

Accounting:

- recent total earnings
- recent total plays
- lifetime total earnings
- lifetime total plays
- clear recent

To save your setting and exit, select the CLOSE option. The system will now reboot. Your screen should now be in the attract mode and ready for play.

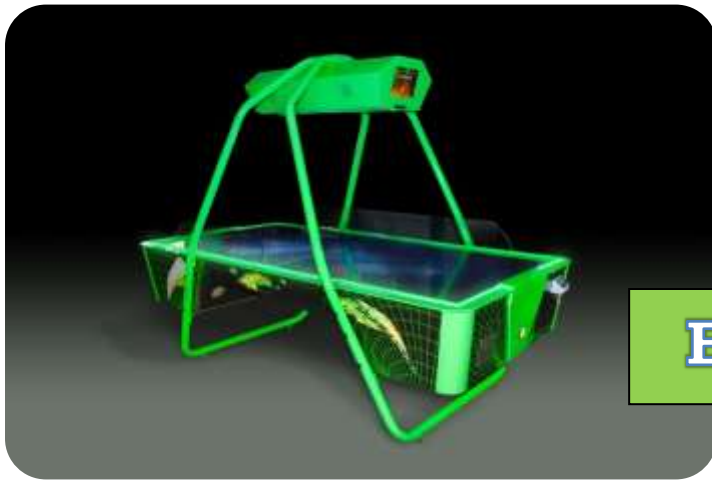

Electronics Layout

If it ever becomes necessary to troubleshoot your Black Hole table's electronics, these "maps" will be a valuable tool.

Black Hole—Behind the Coin Door

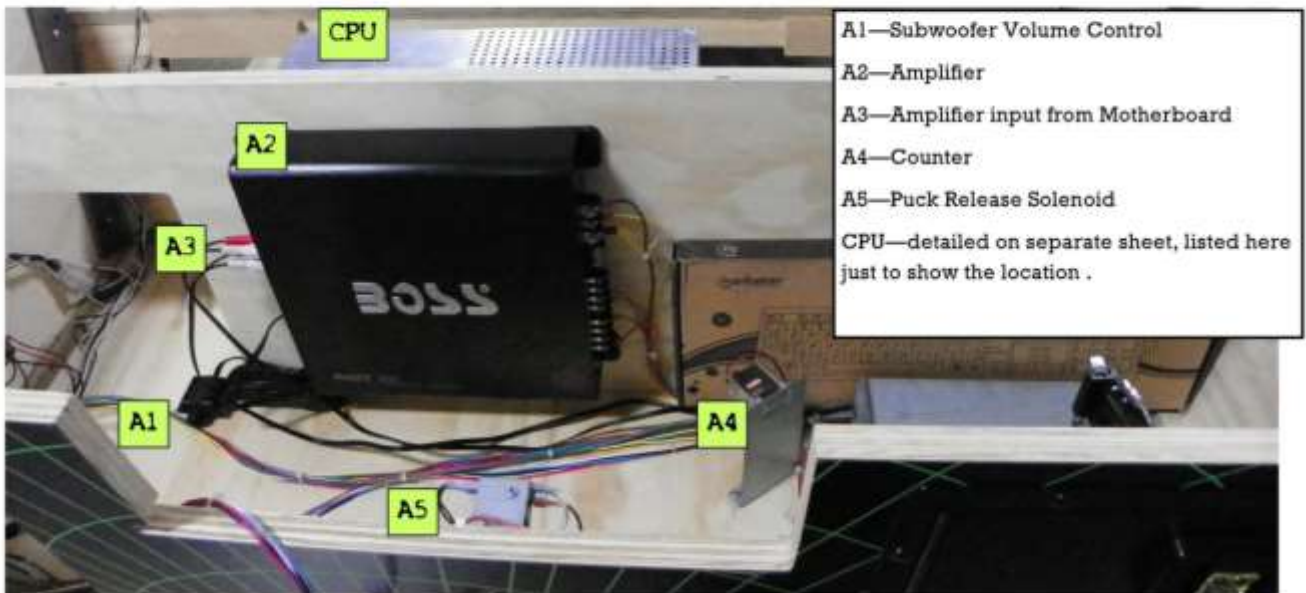

Black Hole—Overall Electronics Layout

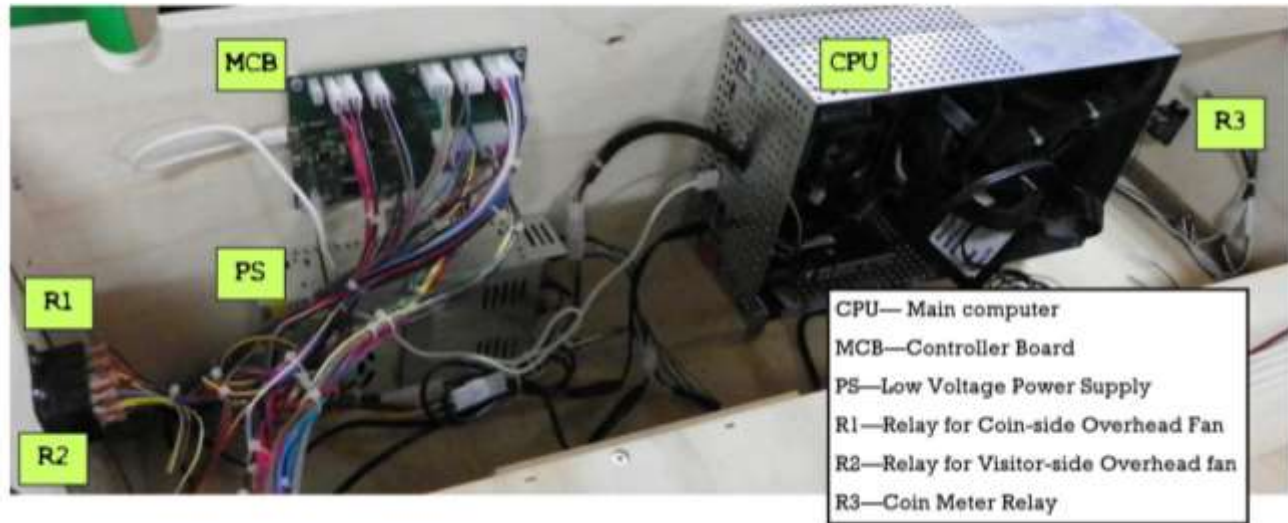

Black Hole — CPU (internal)

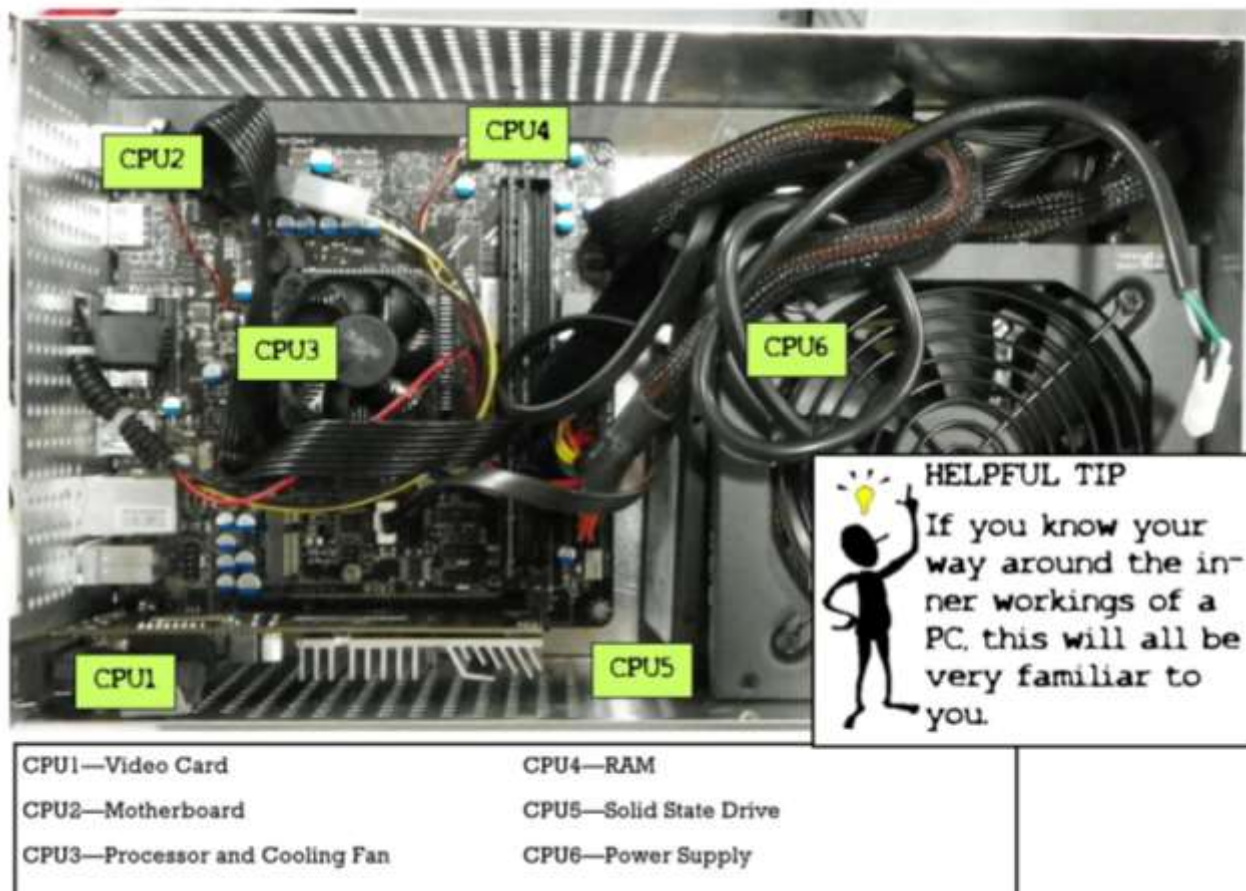

Black Hole — CPU (external)

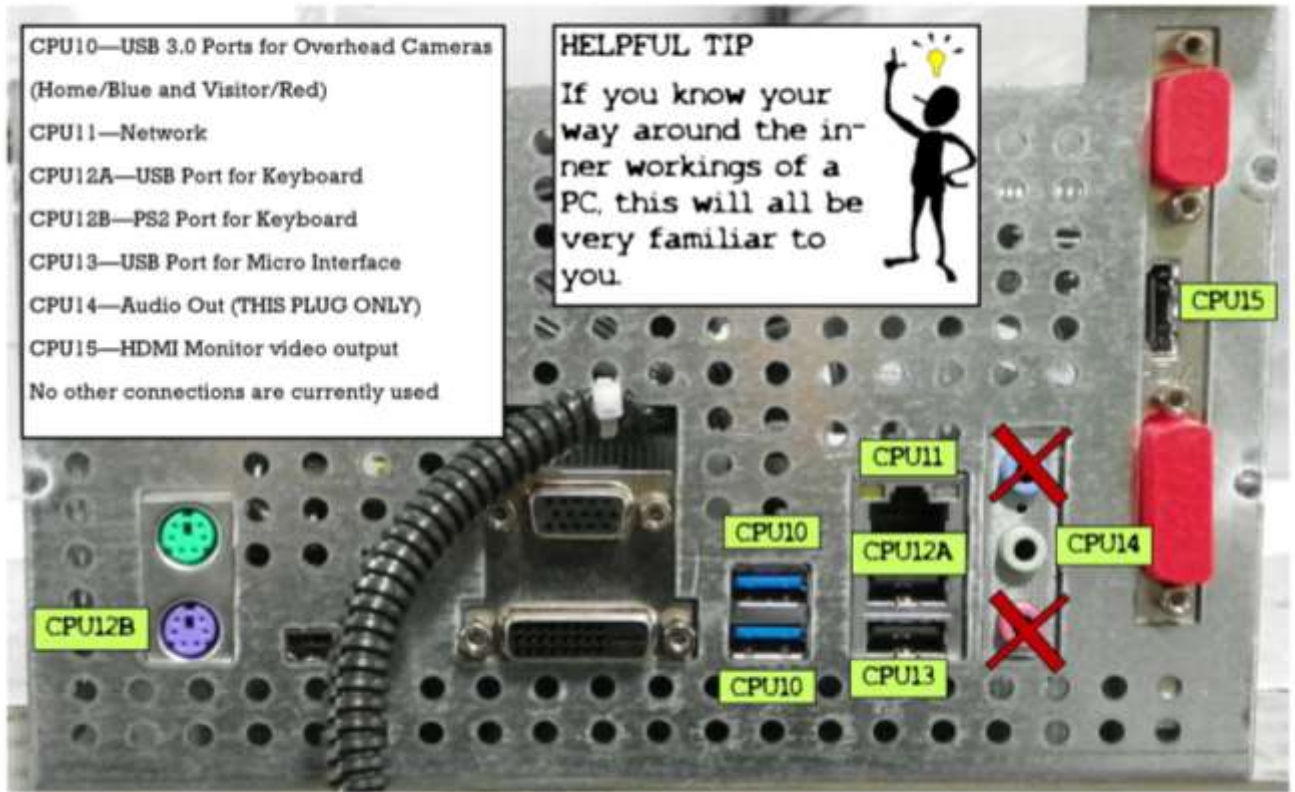

Black Hole — Main Controller PCB

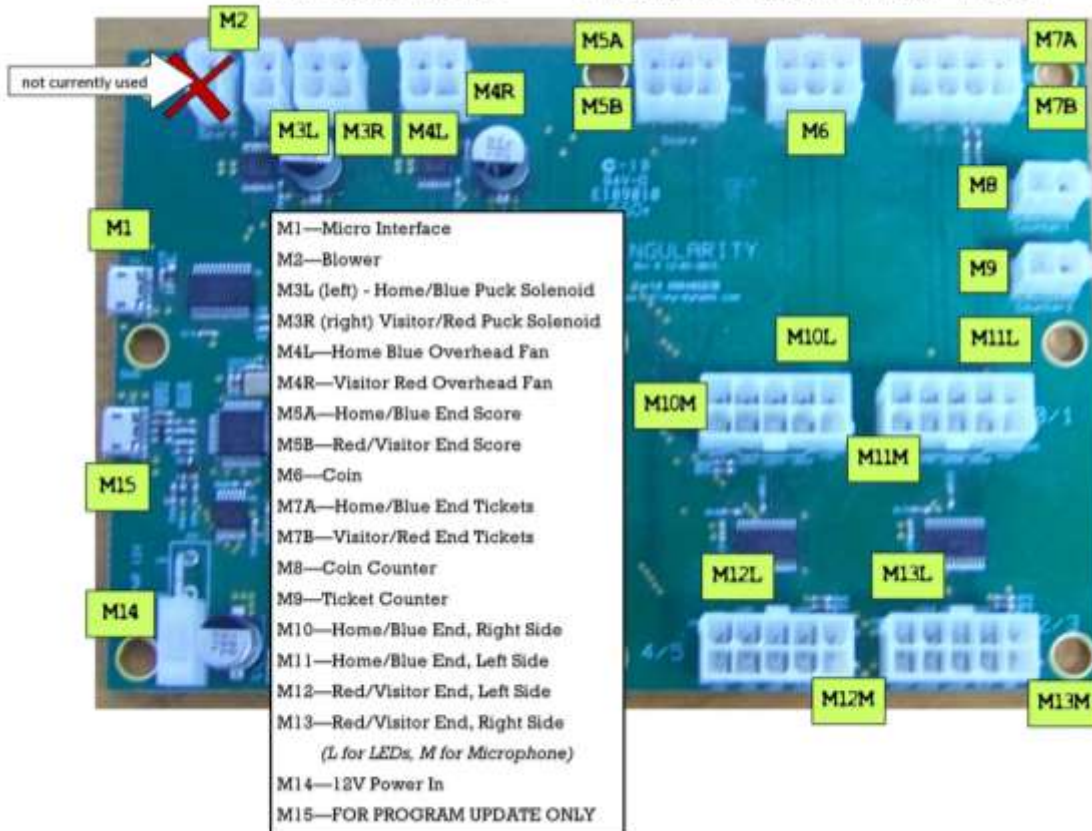

Selected Parts Listing

Part Number	Item Description
860400090	PUCK, FLUORESCENT
860400150	PUCK, FLUORESCENT QUIET WHITE
860400210	MALLET, FLUORESCENT WHITE
980400200	SANDPAPER DISC
030400260	THREE-PIECE SHIELD SET
880400900	BLOWER MOTOR 110V
880400910	BLOWER MOTOR, 220V
980400400	BLOWER MOTOR GASKET
800400990	GOAL-END, LOCK ENTRY, LASER GREEN, BLACK HOLE
030000140	J8045 KEY FOR GOAL ENDS
960402800	PUCK DROP HALF (2 PER END, 4 PER TABLE)
800401800	GOAL ENTRY
880404200	SCORE OPTIC BOARD
880400300	SOLENOID, 120V AC
800402300	SOLENOID BRACKET
870401000	LEG LEVELER - BLACK HOLE
800404931	TUBE, BLACK HOLE, LEG SECTION
800404932	TUBE, BLACK HOLE, MALE OVERHEAD
800404933	TUBE, BLACK HOLE, FEMALE OVERHEAD
800404915	OVERHEAD MOUNTING BRACKET, BLACK HOLE
020407190	PLAYFIELD ASSEMBLY - BLACK HOLE
880406025	HDMI DISPLAY - BLACK HOLE OVERHEAD
880406000	HDMI SPLITTER
800404955	CAMERA BRACKET - BLACK HOLE OVERHEAD
880410025	REPLAY CAMERA
880406015	OVERHEAD FAN
7204GR200	DOWN CORNER - BLACK HOLE LASER GREEN
7204GR800	TOP SIDE RAIL - BLACK HOLE
7204GR810	TOP LEFT END RAIL - BLACK HOLE
7204GR820	TOP RIGHT END RAIL - BLACK HOLE
730450145	LED HARNESS (SIDE)
730450147	LED HARNESS (END)
850404030	LABEL, CAUTION PUCK
860404205	SIDE DECAL, BLACK HOLE
860404200	END DECAL, BLACK HOLE
980000530	#106 LOCK WITH KEY FOR SERVICE DOOR
030000130	#106 KEY FOR SERVICE DOOR

CPU Parts Listing

Items listed are current at the time of publication and subject to change as technology improves and/or components become obsoleted. Contact Technical support with any questions

Part Number	Item Description
880406030	MAIN CONTROLLER PCB, BLACK HOLE
880410020	CPU MOTHER BOARD
880410005	CPU POWER SUPPLY
880406060	MOTHER BOARD RAM
880410000	MOTHER BOARD VIDEO CARD
880410010	CPU
880406016	CPU COOLING FAN
880406055	SUB WOOFER
880410030	POWER AMPLIFIER
880406035	12v SWITCHING MODE GAME POWER SUPPLY

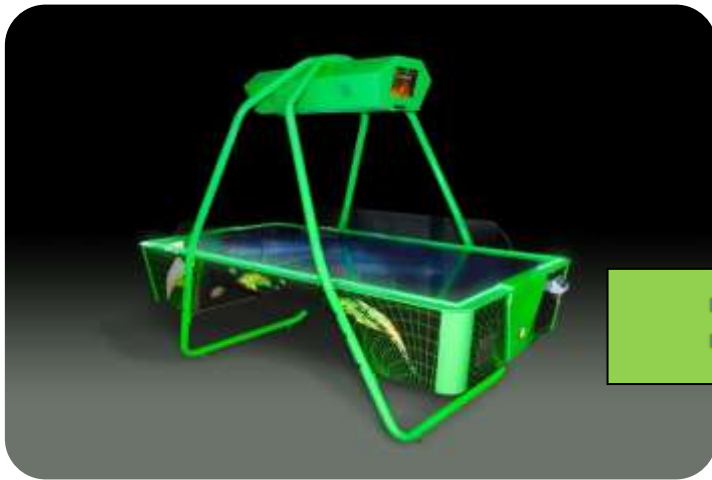

Rules of Play

SCORING

- The first player to score 5 points wins the game.
- A point is scored when the puck enters **and falls into** the goal.
- After a point is scored, the player scored upon receives possession of the puck for the next serve.

CENTERLINE

- If any part of the puck is on the centerline, either player may hit it. If the puck is completely within one player's half of the table, not touching the centerline, the opposing player may **not** hit it. Violation of this rule constitutes a **foul** (forfeiture of possession of the puck).
- It is a foul if a player's mallet **completely** crosses over the centerline.

PUCK OFF THE TABLE

- When a player offensively strikes the puck and causes it to leave the playing surface, that player is guilty of a **foul**.
- If, however, the puck leaves the table while a defensive player is **blocking** a shot, by moving his mallet sideways, backwards, or not at all, the **offensive** player is guilty of a foul and the defensive player gets a possession of the puck.
- If the defensive player charges **forward** to block a shot, and the puck leaves the table, the defensive player commits a foul and loses possession of the puck.

LOSS OF MALLET

- It is a foul for a player to lose total control of his mallet.
- It is a foul for a player to "top" the puck by lifting his mallet and placing it on top of the puck.
- It is a foul when a player's hand, body or clothing touches the puck while the puck is on the table and in play.

GOAL TENDING

- If a player's hand, body or clothing touches the puck while the puck is moving in a direct path toward that player's goal, "goaltending" must be called. Goaltending constitutes a **technical foul**, which allows the opponent a **free shot** at the penalized player's unprotected goal.

7 SECOND RULE

- A player has 7 seconds to execute a shot that crosses the centerline.
- The 7 seconds begins as soon as the puck enters and remains on that player's side of the centerline. Violation of this rule is a foul.

FOULS

- If a player commits a foul and is scored upon in the course of the same play, the goal counts and the penalty is nullified.
- If a foul occurs and the innocent player immediately gains possession of the puck anyway, the referee should simply allow play to continue and not interrupt the game.

MALLETS AND PUCKS

- Mallets and pucks must meet standards and requirements of the U.S. Air-Table Hockey Association.

TOURNAMENT PLAY

- Tournament play shall begin with a coin toss. The winner has the option of the first serve or choosing which end of the table he prefers. Players then alternate first serves **and** table sides for each subsequent game of that match.

REFEREE

- A referee should judge each game in tournament play.

FACE-OFF

- A face-off should be used in a case where the referee is unable to determine which player committed the foul. The puck is placed flat at the center of the table, with the player's mallets allowed no closer than 1/2 inch from the puck. When the referee releases the puck, both players may hit it.

PENALTIES

- A player committing a **Foul** is penalized by loss of possession of the puck.
- A **Technical Foul** allows the penalized player's opponent one **free shot** at the player's unprotected goal. If the free shot misses, the puck is immediately in play.

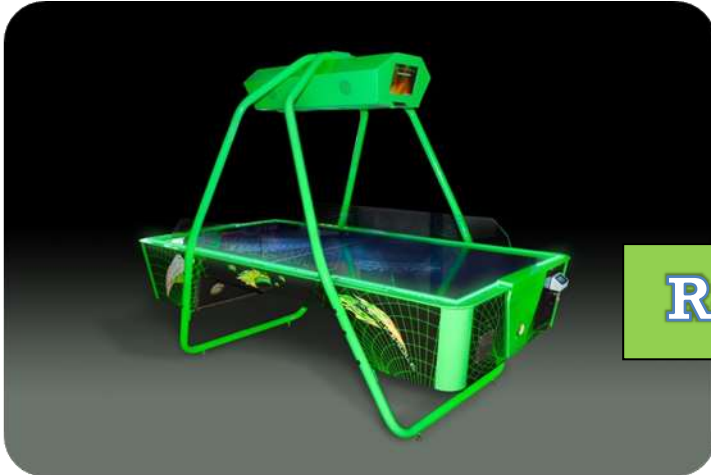

Routine Maintenance

Follow these suggestions to insure your table's maximum earning power and player appeal over the years to come.

PUCKS AND MALLETS: Special pucks and mallets are made for Dynamo Hockey. The pucks and mallets you receive with your table are superior to any others available. For proper play, maximum player enjoyment and the best possible earnings, use high quality pucks and mallets.

It is important to avoid the cheaper, imported pucks. They are slower, lighter, chip more easily, are more susceptible to bending and tend to fly off the table, resulting in loss of play time, player dissatisfaction, and loss of earnings. Because of their inherent instability (i.e.: flying off of the table), there is a risk of player injury when the cheaper pucks are used.

Fluorescent puck: The Dynamo Fluorescent puck (860400090) is made of glass-filled Lexan and was developed specifically for the Dynamo Hockey table. This deluxe puck had been designed and tested for superior speed, visibility, durability and stability on the table. The fluorescent Lexan puck is the best puck on the market and we highly recommend its use to insure a high level of earnings and player appeal.

White quiet puck: We also offer our white quiet puck (860400150) made from a softer, noise-reducing material. The quiet puck is recommended in situations where a quieter table is a necessity.

Fluorescent mallets: Our deluxe mallets (860400210) were designed to give the puck maximum rebound yet absorb the impact and keep it away from the players hands. This took years of testing and balancing to perfect the chemical formula. It seems unimportant and possibly excessive, but the sooner a player's hands hurt the sooner they stop playing. This mallet will also outlast the lightweight imports many times over. Be sure to look for the Dynamo logo on your mallets.

Our pucks and mallets are available from a number of parts distributors as well as www.valleydynamoparts.com. Be sure to specify Dynamo pucks and mallets. We have added our logo to help identify them for you.

SANDPAPER: Adhesive-backed 240-grit sandpaper (980400200) has been included with your table. This should be attached to the side or end of the table, or nearby, so players can sand the puck when it stops floating properly due to small nicks and abrasions. Do not attach the sandpaper to the back of the metal goal end where it could damage clothing. Sandpaper discs (980400200) can be obtained from www.valleydynamoparts.com, Dynamo distributors, a hardware store, or from one of the parts companies supplying this industry. Sandpaper, like pucks and mallets, should be replaced when showing excessive wear.

CLEANING: Excessive dust on the surface of your table will slow the puck significantly. To prevent this, the table should be cleaned once a week -- more often if necessary. We highly recommend rubbing alcohol (isopropyl alcohol) to clean the plastic laminate surface. Liquid window cleaners are also acceptable. Always clean the plastic laminate surface with the air on to ensure that the cleaning process does not force the dirt down into the air holes. Use a small amount of the cleaning solution on a clean paper towel to clean off the dust and dirt. Regular cleaning and maintenance of the playing surface can prevent the holes from becoming plugged.

Once a year or so, check the condition of the air holes. If any debris has been forced down into the air holes, it can be removed with the following method: With the air ON, use a Dremel Moto-tool or equivalent, with a 1/32" drill bit. Slowly insert the rotating drill bit into the hole. This will cause the debris to "ride" up the grooves on the drill bit and out onto the playing surface. Never push the debris down into your table.

When cleaning the table surface, do not clean off the side rails where the puck hits. The thin layer of dirt helps the puck bank properly and keeps it on the table.

NEVER USE SILICONES, WAXES, OR ANY OTHER PRODUCT THAT COULD LEAVE A RESIDUE ON THE PLAYING SURFACE. THE USE OF THESE PRODUCTS WILL CAUSE A BUILDUP OF DEBRIS IN THE AIR HOLES.

LIQUIDS: There should be no drinks placed on the table. Ever. Any liquid spilled on the surface must be wiped up immediately. Large amounts of any liquid can seep down the holes and into the wood, which will warp the playing surface. We recommend prohibiting drinks from being placed on the table at any time. Your table's Side shields are very effective in discouraging placement of drinks on the top rails.

LIQUID SPILLS ARE NOT A COVERED WARRANTY FAILURE.

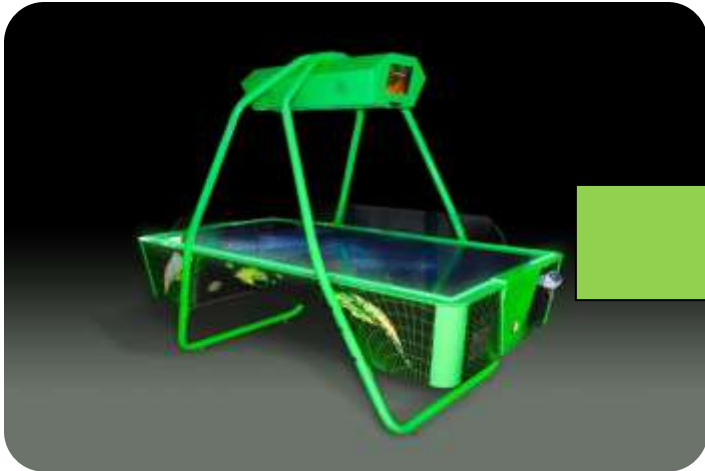

Closing Notes

Just as with the disks and instructions sent with that brand new Computer, Phone, Television, Printer, practically ANY electronic device these days, information can and will change between the time this was printed and the time you reached for the manual. Sometimes between printing and actual purchase.

The most current and complete troubleshooting, technical and parts breakdown information can be found at any time at

www.valleydynamoparts.com

For additional assistance:

Email anytime : techhelp@valley-dynamo.com

**During business hours (Central US Time) : call 972.595.5300
and follow the prompts for Tech support**

We hope your proudly American-built Dynamo Hockey table provides decades of trouble-free enjoyment. Thanks again for choosing Dynamo.





THE PERFECT COMPANION PIECE TO DYNAMO HOCKEY

Perhaps you've heard we make a pretty good pool table too. Dynamo offers programmable pool tables with bill acceptors as well as standard push chute models, in three different sizes. All Dynamo products are proudly built in Richland Hills TX USA.

Contact your distributor today, or check out the full Dynamo line as valley-dynamo.com.